

St Louis Flying Club Annual Meeting 2015

St Louis Flying Club – Annual Meeting- Oct 17, 2015



Agenda



St Louis Flying Club – Annual Meeting- Oct 17, 2015

OLD BUSINESS – CR

- Update on maintenance space between B1/B2.
- Tail wheel instructors – Ballew, Housley and Hecker adequate.
- Review “responsibility list”.

NEW BUSINESS

- Presidents Report - CR
 - Update on member waiting list.
 - Changes/updates to By Laws.
 - Review Arrow incident including repair status
 - Vote on club covering Arrow deductible due to mechanical failure
- VP Report – TJ
 - Current process for tracking medical, BFR, etc.
 - Procedure for lapsed items
 - Insurance Renewal process

Agenda (Con't)



St Louis Flying Club – Annual Meeting- Oct 17, 2015

- Treasurers Report – Pic
 - General Report
 - Status of Approved Expenditures
 - Aircraft Valuations and Share Value
 - Sporty's Rebate Status
- Maintenance – JH
 - Current airplane status.
 - Possible upgrades.
 - Explain normal/emergency gear operation.
- Vote
 - Election of club officers
 - Club paying deductible on Arrow incident.



St Louis Flying Club – Annual Meeting- Oct 17, 2015

Oct 2015 Meeting

Treasurer Report

Flight Time History



St Louis Flying Club – Annual Meeting- Oct 17, 2015

	2007	2008	2009	2010	2011	2012	2013	2014	2015 (thru Oct 15)
Citabria									60
C-172	87	115	112	135	156	142	169	194	117
Arrow	<u>- 0 -</u>	<u>- 0 -</u>	<u>- 0 -</u>	<u>290</u>	<u>246</u>	<u>210</u>	<u>160</u>	<u>127</u>	<u>131</u>
Total	87	115	112	425	402	352	329	321	308
# of Members	8	8	8	16	16	16	16	16	20.1
Avg/Member	10.9	14.4	14.0	26.6	25.1	22.0	20.6	20.1	15.3

Summary Treasurer's Status (Sep 2015)



St Louis Flying Club – Annual Meeting- Oct 17, 2015

• C-172 Value:	\$ 55,940	
• Arrow Value:	\$ 79,914	
• Citabria Value:	\$ 50,633	
• Hangar Improvements:	\$ 6,180	
• Adj Treas – Mo Bill Delta\$	-2,705	
• Est Sale of Avionics	\$ 2,400	
• Citabria Fus. Fabric Fund	\$ 5,000	
• Citabria Upgrade Fund	\$ 2,493	(Parachutes, G Meter)
• Improvement Fund:	\$ 1,600	<u>Est @ TBO</u>
• Citabria Engine Fund:	\$ 3,078	\$21,998
• 172 Engine Fund:	\$ 8,894	\$21,486
• Arrow Engine/Prop Fund:	<u>\$ 20,485</u>	\$28,909
	\$233,912/ 22 = \$10,632	

* Credit Card Cash-back = \$259

C-172

Aircraft Values

Arrow

Base Value (SL-30, GMA-340, GTX-327)	\$37,000
Total Time	5,374 hr
Hr adjustment	-\$245
Hrs SMOH	874 hr
SMOH adjustment	\$1,386
GNS-430 WAAS	\$4,000
Dig FF & GEM (EDM-730)	\$2,600
WX Data Link (GDL-88)	<u>\$3,800</u>
AOPA Vref Estimate	\$49,546

Base Value (SL-30, GMA-340, GTX-327)	\$61,000
Total Time	6,012
Hr adjustment	\$48
Hrs SMOH	1,532
SMOH adjustment	-\$7,448
GTN-750 WAAS	\$14,000
Dig FF & GEM (EDM-830)	\$2,600
WX Data Link (GDL-88)	<u>\$3,800</u>
AOPA Vref Estimate	\$74,000

Paint adjustment (+/- \$6K) 9/2007, 8 yrs	\$500
Interior adjustment (+/- \$5K) 11/2003, 12 yrs	\$-0-

Paint adjustment (+/- \$6K) 3/2009, 6 yrs	\$500
Interior adjustment (+/- \$6K) 2004, 11 yrs	\$0

Additional Adjustments

Traffic Monitor	-
Shoulder Harness Retractors	\$500
Rosen Visors	\$300
406 ELT	\$500
Precise Flow Air Vents	\$500
Standby Vacuum	\$575
Reiff cylinder & oil pan heater	\$500
Falcon MFC Digital Clock & Timer	\$200
Ameriking Avionics Cooling Fan	\$150
PAI-700 Vertical Card Compass	\$300
Flight Stream 210	\$650
AERA-550 & GDL-39 (ADS-B In)	<u>\$1,500</u>

Additional Adjustments

LoPresti Boom Beam	\$800
406 ELT	\$500
LC-2 Quartz Chronometer	\$300
Rosen Visors	\$300
PAI-700 Vertical Card Compass	\$300
Slick Start	\$500
Standby Vacuum	\$575
Flight Stream 210	\$650
Reiff cylinder & oil pan heater	\$500

Roll-up	\$54,716
Adjustment	<u>\$0</u>
Market Value	\$54,716
Sep 2015 Value	\$55,940
	-\$1,224

Roll-Up	\$78,925
Adjustment	<u>\$0</u>
Market Value	\$78,925
Sep 2015 Value	\$79,914
	-\$989

Citabria Value

Base Value (w NavCom & Xponder)	\$28,000
Total Time	2,032 hr
Hr adjustment	\$1,362
Hrs SMOH	295 hr
SMOH adjustment	\$9,050
Metal Spar Wing (New \$21,990)	<u>\$17,500</u>
AOPA Vref Estimate	\$55,912

Fuselage Fabric (+/- \$4K)	-\$5,000
Interior adjustment (+/- \$2K)	-\$250

Additional Adjustments

Garmin 496	\$800
Aileron Spades	\$650
Hooker Harnesses	\$500
Spin On Oil Filter, Vert Card Compass	\$700
Roll-up	\$53,312
Market Adjustment	<u>-\$2,679</u>
Market Value	<u>\$50,633</u>
Sep 2015 Value	<u>\$50,633</u>

\$-0-

Status of Approved Expenditures

Meeting Approved	Item	A/C	Authorized	Actual	Over (-)/ Underrun
May-14	Lockers	-----	\$1,400	\$1,971	(\$571)
Nov-14	FS 210	C-172	\$650	\$856	(\$206)
May-14	GDL-88	Arrow	\$3,205	\$3,205	\$0
Nov-14	FS-210	Arrow	\$650	\$856	(\$206)
Nov-14	GMA-340	Arrow	\$1,610	\$1,008	\$602
Nov-14	GTX-327	Arrow	\$1,740	\$1,268	\$472
Nov-14	SL-30	Arrow	\$3,800	\$3,315	\$485
Nov-14	GTN-750	Arrow	\$13,700	\$13,710	(\$10)
Nov-14	430W	Arrow	-\$6,700	-\$6,800	\$100
Nov-14	King Nav/Com	Arrow	-\$1,500	-\$1,800	\$300
Nov-14	Aera & Gizmo	Arrow	-\$700	To Install in Citabria	
Oct-15	Garmin 496/Gizmo	Citabria		-\$500 Est	
Nov-14	King Xponder	Arrow	-\$400	Installed in Citabria	
Oct-15	King Xponder	Citabria		-\$300 Est	
Nov-14	GDL-39	Arrow	-\$500	To Install in Citabria	
Nov-14	King ADF	Arrow	-\$300	-\$300 Est	
Nov-14	King Audio Pnl	Arrow	-\$300	-\$300 Est	
Nov-14	King DME	Arrow	-\$400	-\$400 Est	
	Annunciator	Arrow	\$0	\$200	(\$200)
			\$15,955	\$15,989	\$367

Had estimated an Add'l \$2,400 from Avionics sale – Now estimating \$1,800 with swap w/Citabria

Citabria Maintenance/Upgrades



St Louis Flying Club – Annual Meeting- Oct 17, 2015



- April - Upgraded Transponder KT-76A to KT-76C
- May
 - Upgraded Navigation lights to LED lights
 - Replaced tail wheel springs
- June – Replaced oil screen with Oil Filter Adapter
- Aug
 - Installed new LH Wing Jury strut and eye bolts
 - Installed new Tail Wheel Tire and tube
- Oct/Nov
 - Annual Inspection – Due in Dec – Plan to move up one month to Nov

Cessna Maintenance/Upgrades



St Louis Flying Club – Annual Meeting- Oct 17, 2015



- January
 - Rebuilt nose strut & added shims to fix shimmy issue
 - Installed FS-210 unit
- April – Installed overhauled Attitude Indicator
- July
 - Seat Rail AD Inspection – Next due at 5474.7 hours
 - Repaired Pilot door handle push rod
- September – Replaced LH Main Tire, Tube and brake pads
- October – Annual Inspection completed Oct 16

Arrow Maintenance/Upgrades



St Louis Flying Club – Annual Meeting- Oct 17, 2015



- January – Replaced oil door latch and striker plate
- March – Replaced nose tire and tube
- May – Avionics upgrade – GTN-750, GMA-340, GTX-327, SL-30, FS-210, GDL-88, EDM-830, Annunciator Panel, Standby Vacuum, CO Monitor
- July – Installed Panel Light Dimmer Transistor
 - Replaced LH tire, tube, and brake pads
- August – Replaced Attitude Indicator with OH unit, replaced Panel dimmer potentiometer
- September/October – Air Associates Repair in progress

Arrow Landing Gear



St Louis Flying Club – Annual Meeting- Oct 17, 2015

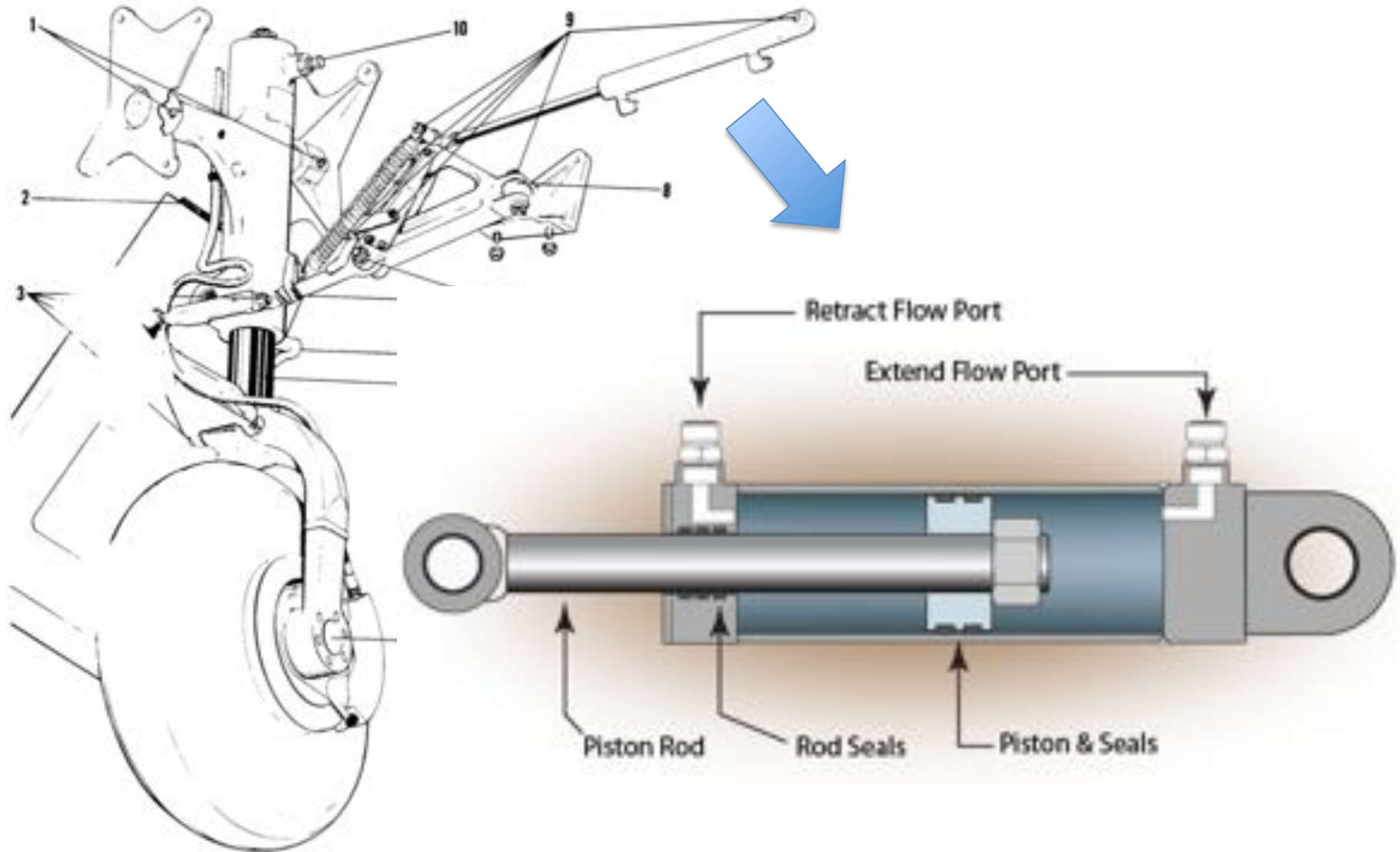

Citabria - Improvements



St Louis Flying Club – Annual Meeting- Oct 17, 2015

- Citabria Upgrades
 - Hooker Harnesses – Purchased
 - Replace Cowl Fasteners – Purchased
 - Vertical Card Compass - Purchased
 - Engine/Oil Heater - Purchased
 - Battery Trickle charger/Cable – Purchased
 - Parachutes - \$1,500 budgeted
 - Panel Upgrade – In planning stages
 - More front seat room for front pilot – See options
 - ADS-B – Leaning toward GDL-84
 - Rotating Beacon – Plan to remove since wing tip strobes meet requirement (save weight and lower drag)



Citabria front Seat Room



St Louis Flying Club – Annual Meeting- Oct 17, 2015

- Options Considered

1. Adjustable Front Seat - \$995 for adjustable seat from American Champion

- Requires new rear stick to clear \$115.00 or mod to existing stick
- Easily adjustable with pull of adjustment handle

2. Add seat rails to allow 2 inch adjustment

- Field approval needed – Rear stick cable adjustment required
- Requires 4 bolts/nuts to be removed and reinstalled to adjust seat position

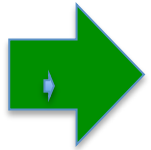

3. Modification to Front Seat back upholstery to allow thin and thick seat backs to attach with Velcro. Working on estimates

Recommended Option 3



St Louis Flying Club – Annual Meeting- Oct 17, 2015

- Rework front seat upholstery to allow thick and thin seat back cushion to attach with Velcro.

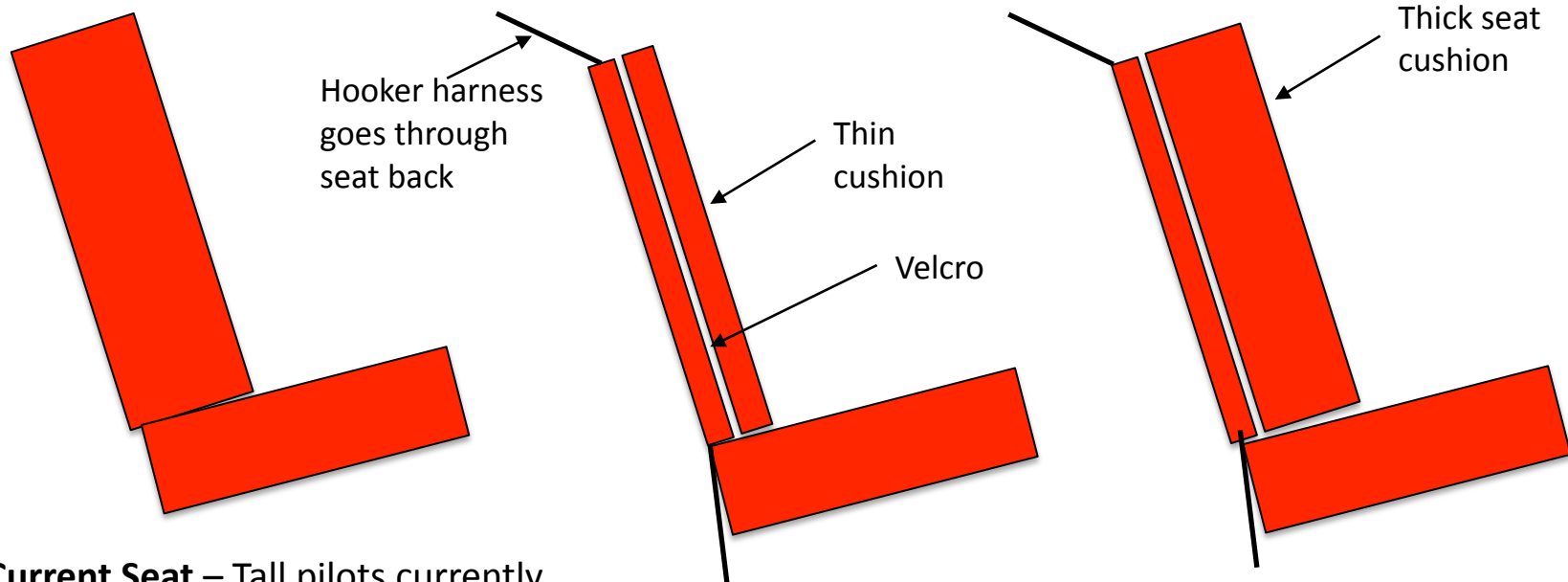

Current Seat – Tall pilots currently removing whole seat back and putting thin pad in its place- Won't work when Hooker Harness is installed

Modified Seat – Tall pilots install thin seat back cushion and normal pilots would install thicker cushion

Option 3



St Louis Flying Club – Annual Meeting- Oct 17, 2015



Current Model Citabria Seat – Shows fixed seat back upholstery with removable seat cushion

Instrument Panel Upgrade



St Louis Flying Club – Annual Meeting- Oct 17, 2015

- Current Instrument panel



Panel Upgrade



St Louis Flying Club – Annual Meeting- Oct 17, 2015

Remove GPS– Install Arrow AERA and GDL-39
Remove CDI – Install G Meter \$420



Upgrade 1

Remove CDI and install 3 1/8" +5/-2G G-Meter in its place. Remove 496 GPS and install AERA-550 with GDL-39 for weather & some traffic.

GRT Mini X Display



St Louis Flying Club – Annual Meeting- Oct 17, 2015

- Could add to Citabria as reference display
 - Has G-Meter, Vertical speed, Heading, Airspeed, Attitude, skid indicator,



Photo of display at Oshkosh showing G-Meter

Panel Options



St Louis Flying Club – Annual Meeting- Oct 17, 2015

Potential future options with Flight Display and digital Engine Monitor to make room for Display



Citabria ADS-B Planning



St Louis Flying Club – Annual Meeting- Oct 17, 2015

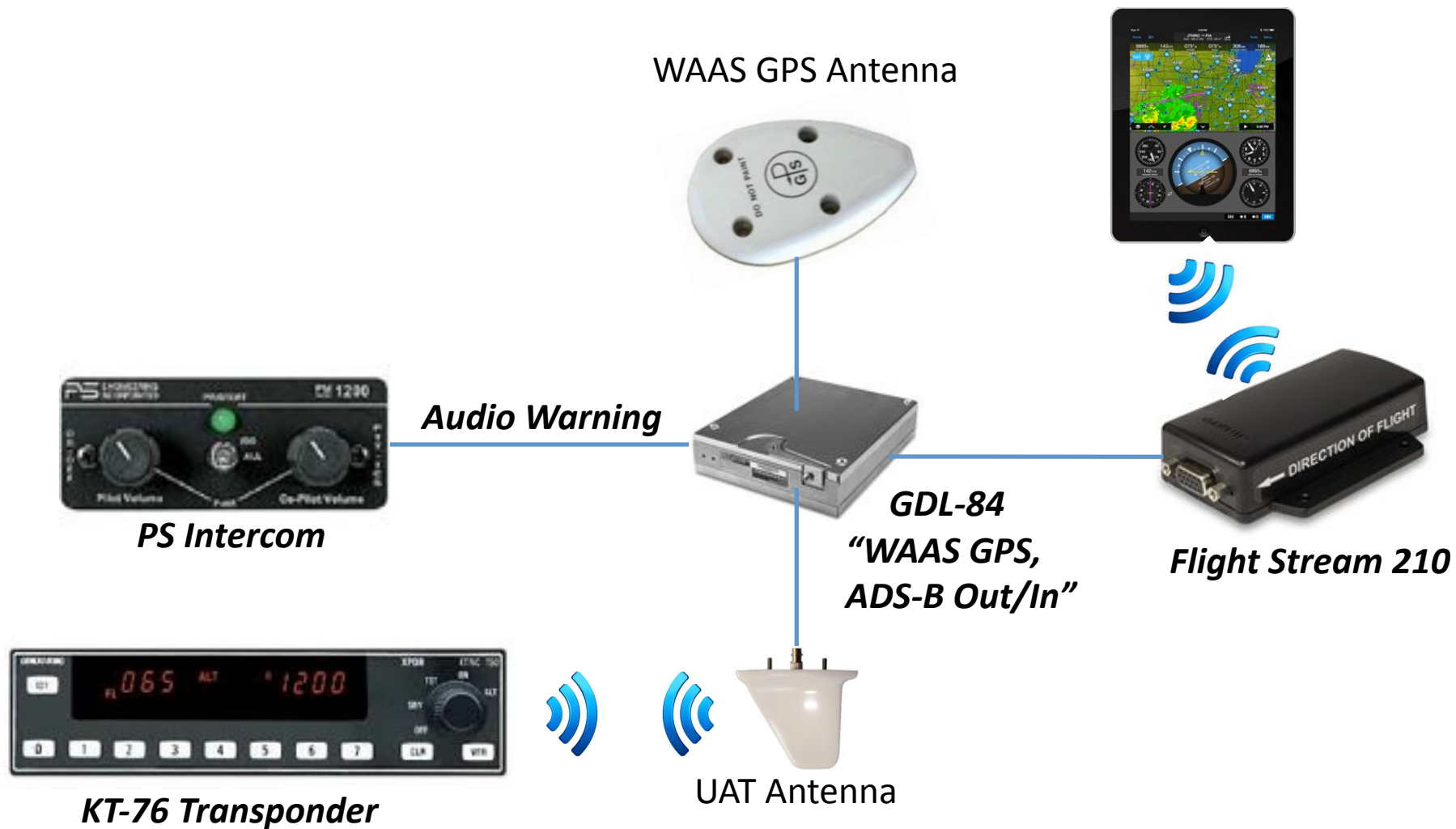

AOA Indicator



St Louis Flying Club – Annual Meeting- Oct 17, 2015



FACTS ON THE FLY:

- Angle of Attack (AOA) and airspeed mismanagement account for the majority of preventable fatal loss of control accidents that occur in the traffic pattern and on approach
- The KLR 10 Lift Reserve Indicator provides warnings of a low lift margin well in advance of an aerodynamic stall.
- The KLR 10 improves operational safety by increasing pilot awareness of remaining lift during high ADA flight phases such as maximum performance climb, traffic pattern maneuvering, approach and landing

\$1,600

Can be mounted on glare shield or in instrument panel if space available

Portable Air Conditioner



St Louis Flying Club – Annual Meeting- Oct 17, 2015



- Low cost solution to cooling
- 40° F vented cool air
- Provides up to two (2) hours of cool air
- Holds up to 20 Lbs of ice
- 12 volt plug
- Dimensions: 18"W x 13"D x 15"H.
- Approximately 10 pounds (empty).

\$299

Facility Upgrades



St Louis Flying Club – Annual Meeting- Oct 17, 2015

- Construct Pass through to Citabria Hangar
- Add Circuit breaker Box and install Ceiling lights and power sockets
- Add sheet metal siding to club facility perimeter
- Will schedule work when Jerry's scaffolding and ladder are available

